

VIEW A

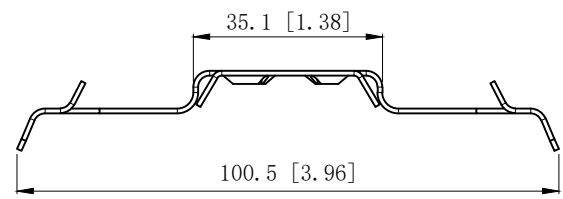
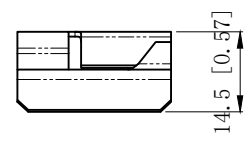
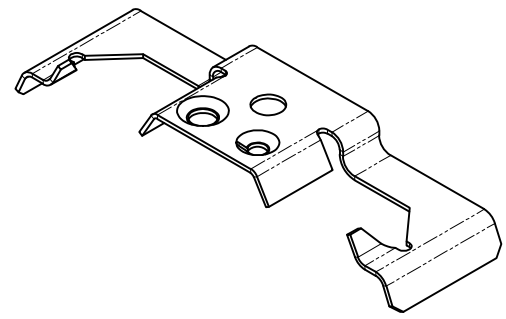

- NOTES(技术要求):
- 1.All dimensions in millimeters and [inches](所有尺寸单位为毫米与 [英寸]);
 - 2.Material:C1065 spring steel .thickness:0.9mm[0.035](材料:65号弹簧钢,厚度:0.9mm[0.035]),
Finish: Dacromet(表面处理:达克罗);
 - 3.Free of sharp edge and burrs.max burr 0.127[0.005](去除毛刺,尖角倒圆,最大毛刺 0.127[0.005]);
 - 4.Hardness: HRC 38~45(洛氏硬度 38~45);

WINNIE INDUSTRIES		
SIZE A4	DWG NO. WHK200	REV