

IT IS PUNCHING THREAD HOLE
FOR FITTING #1/4-20 SCREW

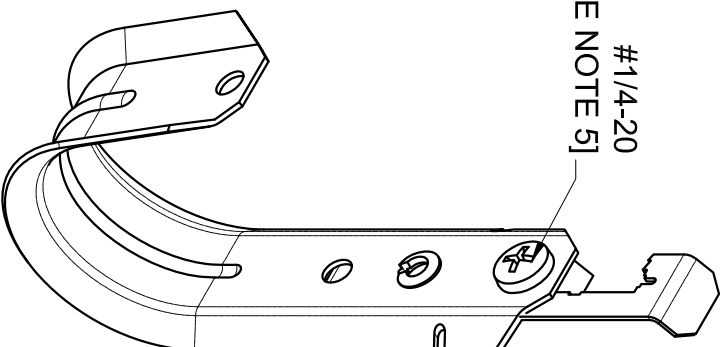
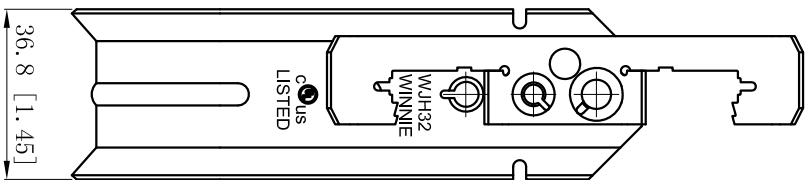
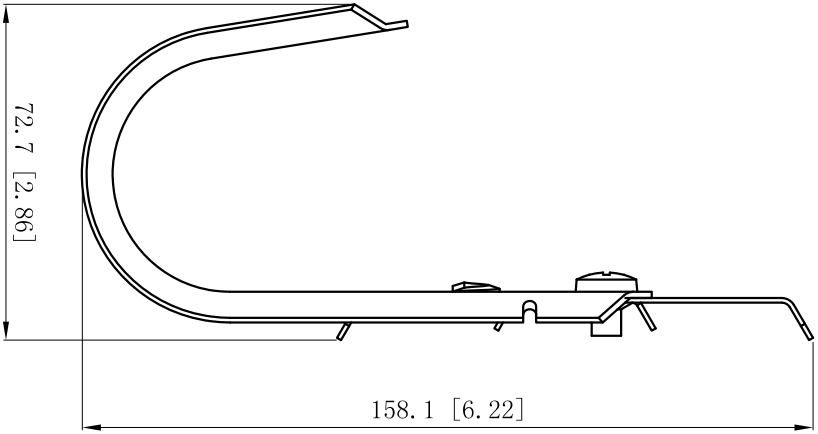
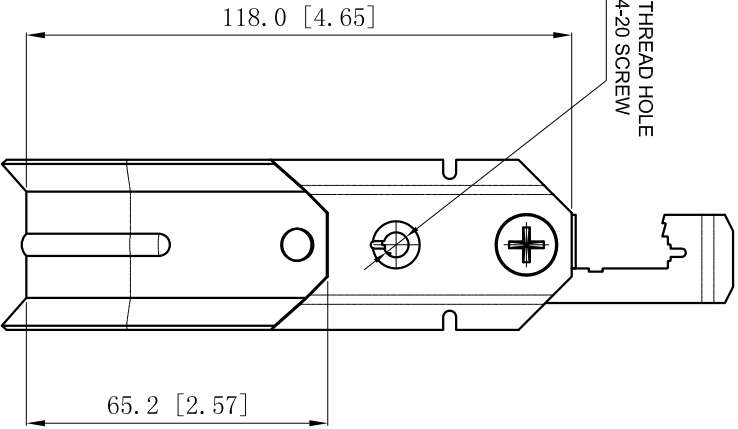

NOTES:

1. All dimensions in millimeters and [inches];
2. Free of sharp edge and burrs, max burr 0.127[0.005].
3. Material: Pre galvanized (G60) , Thickness: 1.35mm [0.053] .
4. Every carton need one instruction sheet, the instruction need spring front and back
5. 1pcs #1/4-20 x 3/8 combo philips/slotted round head machine screw, zinc plated;

WINNIE INDUSTRIES		
SIZE	DWG NO.	REV
A4	WJH32W	