

REVISIONS		
SYM.	BY.	DATE
A		

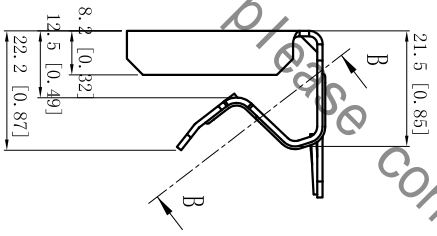

CUTAWAY VIEW B-B

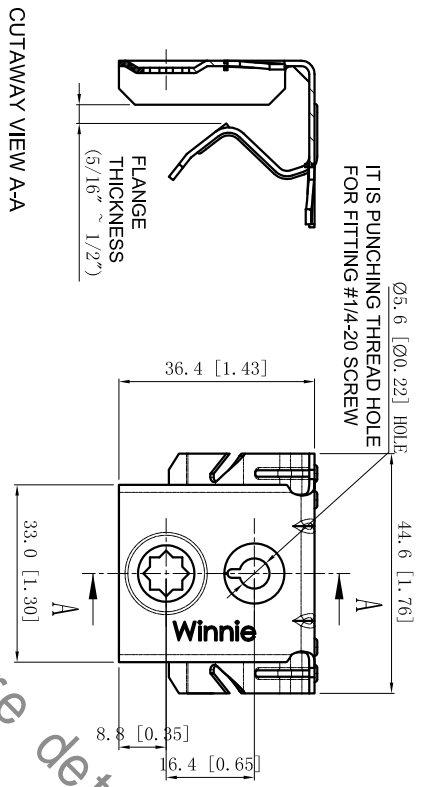
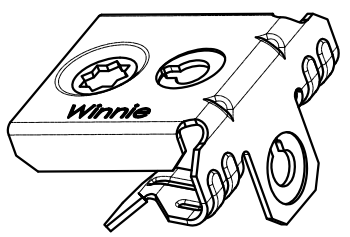
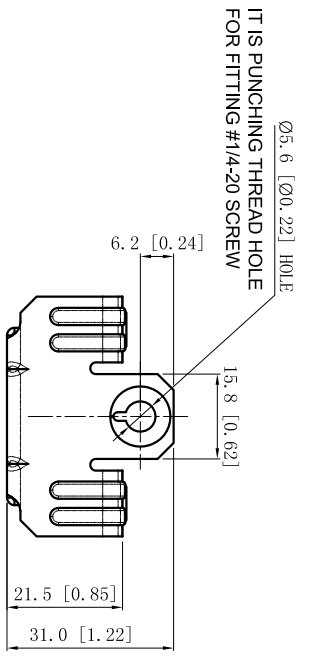
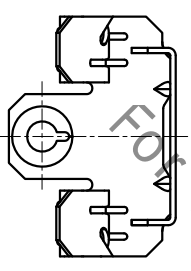
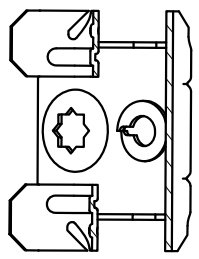

CUTAWAY VIEW A-A

- NOTES:
- 1.All dimensions in millimeters and [inches];
  - 2.Material:C1065 spring steel .thickness:1.20mm[0.047].
  - 3.Free of sharp edge and burrs,max burr 0.127[0.005].
- Finish: Dacromet;

WINNIE INDUSTRIES		
SIZE	DWG NO.	REV
A4	WM58	