

CUTAWAY VIEW A-A

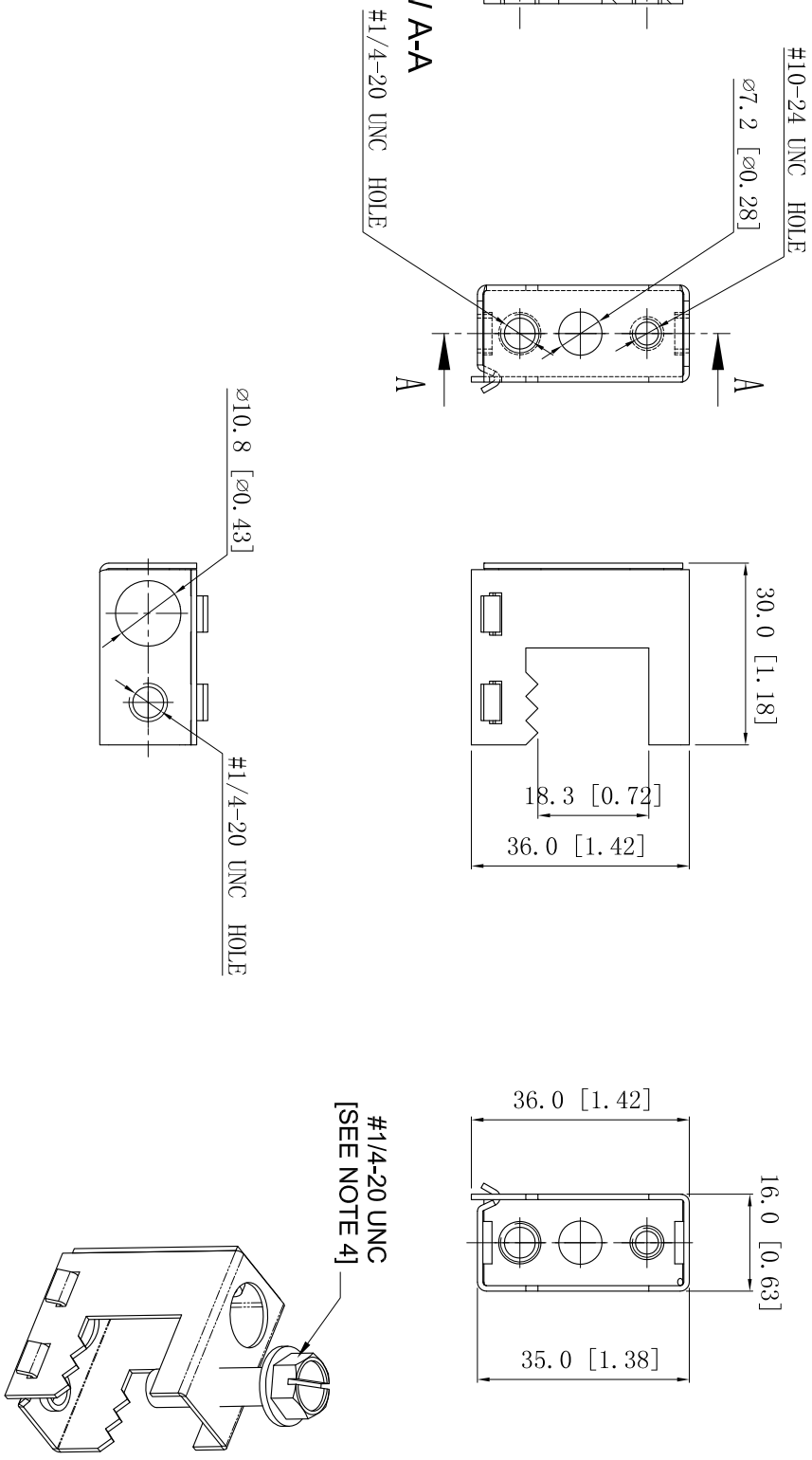

NOTES:

1. All dimensions in millimeters and [inches];
2. Material: C1065 spring steel . thickness: 0.8mm [0.031],
Finish: E-coat
3. Free of sharp edge and burrs. max burr 0.127 [0.005];
4. #1/4-20 x 1 slotted flange hex head cup point machine
screw, case harden;
Finish: Black Oxide .

WINNIE INDUSTRIES		
SIZE	DWG NO.	
A4	WSSBC	
REV		A